

  
**AIR  
TECHNOLOGY**  
CORPORATION, S.A. DE C.V.

**CAB-DI**



**Aero ventiladores centrífugos ATC tipo gabinete  
Descarga Horizontal y Vertical**

ATC centrifugal forward curved cabinet fans  
Horizontal and Vertical discharge



**The Right Choice**

CAB-DI



# CAB-DI

## Indice

Características principales	2
Especificaciones técnicas	4
Curvas de operación	5
Dimensiones generales	16
Arreglos de los filtros-louvers	22

## Table of Contents

Construction features	3
Performance data	4
Performance curves	5
Dimensions	16
Filter-louver arrangement	22



## CAB-DI

### Aero ventiladores centrífugos ATC tipo gabinete Descarga Horizontal y Vertical

Las unidades de ventilación CAB tipo gabinete con turbinas de doble aspiración y álabes curvos adelantados y transmisión de poleas y bandas, han sido especialmente diseñadas para sistemas de inyección y extracción de aire limpio en aplicaciones comerciales e industriales. La línea CAB está disponible en 11 modelos diferentes con descarga horizontal y vertical con opción de una o dos etapas de filtración ( filtros metálicos lavables y/o filtros de panel plisado) manejando grandes caudales de aire a medianas presiones estáticas con un mínimo nivel sonoro y bajo consumo de energía.

#### Aplicaciones

Unidades manejadoras de aire acondicionado, calefacción, enfriadores evaporativos, unidades de ventilación con filtros para la industria farmacéutica, alimenticia, centros comerciales, plantas industriales, etc.

#### Características principales

- El gabinete de la unidad de ventilación está fabricada en lámina galvanizada o pintor en diferentes calibres según tamaño, cuenta con perfiles estructurales, puertas de inspección con bisagras, jaladeras, cierras y levas de presión, una base rígida para montaje e izaje y cuellos rígidos en descarga y succión para facilitar el acoplamiento al sistema de ductos.
- Equipadas al interior del gabinete con ventilador centrífugo ATC de doble oído de aspiración modelo DI con turbina centrífuga de alta eficiencia de álabes curvos adelantados fabricada en lámina galvanizada o acero al carbón con aplicación electrostática de pintura poliéster en polvo horneada altamente resistente a la corrosión e intemperie.
- Disponibles en 2 posiciones de descarga: horizontal-vertical, 2 distintas rotaciones de la turbina: CW-CCW, 3 posiciones de montaje de motor: sobre una base con rieles en piso, sobre un bastidor común con perfiles estructurales y sobre envoltorio del ventilador ( diseño compacto ).
- Chumaceras o rodamientos de alta eficiencia y mínimo mantenimiento, diseñados para aplicaciones industriales adquiridos de fabricantes mundialmente reconocidos.

- Flechas o ejes impulsores seleccionados en diferentes diámetros y longitudes según tamaño del ventilador, fabricados en acero AISI C-1045, perfectamente pulidos y rectificadas en toda su longitud y protegidos con un recubrimiento anticorrosivo.
- Base ajustable de motor fabricada en acero al carbón o lámina galvanizada y diseñada para ajuste, alineación y tensión de las bandas con una precisión y rapidez.
- Los ventiladores centrífugos marca ATC modelo DI cuentan con junta antivibratoria de lona ahulada para su conexión al gabinete y soporte bastidor para montaje e izaje con barreno para el acoplamiento de tacones o resortes antivibratorios como accesorios de control de ruido y vibración.
- Accionado por transmisión de poleas y bandas a los motores eléctricos de alta eficiencia diseñados bajo especificaciones NEMA, permitiendo lograr las distintas relaciones de caudal y presión.

#### Nomenclatura:

**CAB - DI H - F - 20 / 20 - CW**

1	2	3	4	5	6	7
---	---	---	---	---	---	---

1. Modelo del ventilador tipo gabinete.
2. Ventilador con doble aspiración
3. Posición de la descarga  
H : Descarga Horizontal  
V : Descarga Vertical
4. Etapas de filtración  
F : Una etapa de filtración (filtros metálicos lavables)  
FF : Doble etapa de filtración ( filtros metálicos lavables y filtros de papel plisado ).
5. Diámetro aproximado de la turbina en pulgadas.
6. Ancho aproximado de la turbina en pulgadas.
7. Rotación de la turbina  
CW : Sentido del reloj  
CCW : Sentido contra reloj



# CAB-DI

## ATC centrifugal forward curved cabinet fans Horizontal and Vertical discharge

The CAB-DI series are belt driven, double inlet centrifugal forward curved cabinet fans, specifically designed for duct applications handling relatively clean air in supply, exhaust and return air systems. These line of ATC cabinet fans are available in 11 different models ranging from 9" through 36" wheel diameters, horizontal and vertical air flow positions, optional filter sections with one or two stages of filtration (aluminum) washable metallic filters and pleated panel filters). These cabinet fans are manufactured under strict quality assurance standards to ensure high efficiency and quiet operation in a compact design which produce high air volumes at low speeds.

### Applications

Heating, ventilation, air conditioning units and evaporative coolers in pharmaceutical, food industries, commercial centers, industrial manufacturing plants, etc.

### Construction features

- Housings, scrolls, inlet cones, drive stands and all structural supports are made of heavy gauge galvanized steel construction.
- Side or rear panels provide easy access for service and maintenance to blower, motor and filters without the need to remove duct connections. Access panels are secured with pressure locks that open quickly and easily with the push and turn of a handle.
- An ATC double inlet forward curved blower model DI is installed within each cabinet fan. Blower is firmly mounted on two heavy gauge steel reinforcing channels which contain holes for rubber mounting, resulting in quiet operation.
- Duct collars provide ready attachment to duct work.
- Self-aligning heavy duty pillow blocks ball bearings are designed to operate under the most severe atmospheric conditions and are supplied by the most prestigious world wide manufacturers.
- Shafts are designed for long life in different diameters and lengths, turned, ground and polished of solid SAE 1045 steel for smooth operation, key-wayed and protected with a corrosion resistant coating.

- Blower outlet is connected to a flexible duct connection within the cabinet to aide in anti-vibration.
- The CAB-DI series are the ideal choice for the general belt drive ventilation applications, using the combination of high quality sheaves, v belts, high efficiency motors in order to handle a wide range of air volumes and pressures.

### Nomenclature:

**CAB - DI H - F - 20 / 20 - CW**

1	2	3	4	5	6	7
---	---	---	---	---	---	---

1. Cabinet Fan model
2. Double inlet fan
3. Discharge position  
H : Horizontal discharge  
V : Vertical discharge
4. Filter stages  
F : One stage filtration (Aluminium washable metallic filters)  
FF : Two stage filtration (Washable metallic filters and pleated panel filters)
5. Wheel diameter in inches
6. Wheel width in inches
7. Wheel rotation  
CW : Clockwise  
CCW : Counter clockwise

## Especificaciones técnicas / Performance data

Modelo Model	CFM	0.25" SP		0.5" SP		0.75" SP		1.00" SP	
		RPM	BHP	RPM	BHP	RPM	BHP	RPM	BHP
DI-9/6	400	556	0.07	783	0.11	992	0.15	1156	0.19
	600	575	0.09	769	0.13	950	0.17	1102	0.21
	800	630	0.12	794	0.16	958	0.21	1092	0.25
	1000	700	0.18	845	0.22	986	0.27	1100	0.37
DI-9/9	600	566	0.10	788	0.14	998	0.20	1148	0.25
	800	589	0.12	787	0.16	972	0.23	1127	0.29
	1000	623	0.15	803	0.20	964	0.27	1109	0.33
	1200	663	0.19	828	0.25	980	0.33	1111	0.39
	1400	710	0.25	863	0.32	1005	0.40	1123	0.47
DI-10/10	800	490	0.13	700	0.20	859	0.28	1002	0.37
	1000	507	0.16	693	0.21	843	0.30	977	0.38
	1200	529	0.18	705	0.26	841	0.33	967	0.42
	1400	558	0.22	718	0.29	847	0.38	968	0.46
	1600	591	0.25	739	0.34	863	0.43	987	0.53
	1800	635	0.32	763	0.40	883	0.50	991	0.60

Modelo Model	CFM	0.25"		0.5"		0.75"		1.00"		1.25"		1.5"		1.75"		2.00"		2.25"		2.50"		
		RPM	BHP	RPM	BHP	RPM	BHP	RPM	BHP	RPM	BHP	RPM	BHP	RPM	BHP	RPM	BHP	RPM	BHP	RPM	BHP	
DI-12/12	1400	409	0.11	571	0.17	706	0.27	823	0.37	*	*	*	*	*	*	*	*	*	*	*	*	
	1600	416	0.13	571	0.22	701	0.32	815	0.42	919	0.53	*	*	*	*	*	*	*	*	*	*	
	1800	425	0.16	574	0.26	699	0.36	810	0.47	911	0.59	*	*	*	*	*	*	*	*	*	*	
	2000	439	0.20	579	0.31	700	0.42	808	0.53	906	0.66	997	0.78	*	*	*	*	*	*	*	*	
	2200	457	0.25	585	0.36	703	0.48	808	0.60	903	0.73	992	0.86	*	*	*	*	*	*	*	*	
	2400	480	0.31	594	0.42	708	0.55	810	0.68	903	0.81	989	0.96	1071	1.01	1149	1.25	*	*	*	*	
	2600	505	0.38	604	0.48	714	0.62	813	0.76	904	0.91	989	1.06	1069	1.21	1145	1.37	1217	1.53	1287	1.70	
	2800	533	0.46	618	0.56	721	0.70	818	0.85	907	1.01	990	1.16	1068	1.32	1142	1.49	1213	1.66	1282	1.83	
	3000	561	0.56	635	0.65	730	0.79	824	0.85	911	1.12	993	1.28	1069	1.45	1142	1.62	1211	1.80	1278	1.98	
	3200	X	X	656	0.76	741	0.90	831	1.06	917	1.24	996	1.41	1071	1.59	1143	1.77	1211	1.95	1277	2.14	
	3400	X	X	679	0.88	755	1.01	840	1.18	923	1.36	1001	1.55	1075	1.74	1145	1.92	1212	2.11	1277	2.31	
	3600	X	X	704	1.02	771	1.15	850	1.31	930	1.50	1007	1.70	1080	1.89	1149	2.09	1214	2.29	1278	2.49	
	3800	X	X	731	1.17	791	1.30	862	1.46	939	1.65	1014	1.85	1085	2.06	1153	2.27	1218	2.48	1280	2.69	
	4000	X	X	X	X	812	1.46	877	1.62	949	1.82	1021	2.02	1091	2.24	1158	2.46	1222	2.67	1284	2.89	
	DI-15/15	2000	341	0.14	474	0.26	587	0.39	686	0.53	*	*	*	*	*	*	*	*	*	*	*	*
		2500	355	0.21	476	0.34	581	0.48	675	0.64	760	0.81	839	0.99	911	1.17	*	*	*	*	*	*
3000		376	0.31	486	0.45	583	0.61	670	0.78	752	0.96	827	1.16	899	1.36	965	1.57	1029	1.78	1089	2.00	
3500		406	0.45	501	0.59	591	0.76	673	0.95	750	1.14	822	1.35	890	1.57	955	1.80	1017	2.03	1076	2.27	
4000		441	0.63	521	0.78	604	0.96	681	1.16	754	1.36	822	1.59	887	1.82	949	2.06	1009	2.31	1066	2.56	
4500		x	x	546	1.01	621	1.20	694	1.41	762	1.63	827	1.86	889	2.11	948	2.36	1006	2.62	1061	2.90	
5000		x	x	577	1.30	642	1.49	710	1.71	775	1.95	837	2.19	896	2.45	953	2.72	1007	2.99	*	*	
5500	x	x	612	1.65	668	1.85	729	2.08	790	2.30	849	2.58	906	2.85	961	3.13	*	*	*	*		
DI-18/18	3000	299	0.25	411	0.45	506	0.69	588	0.93	660	1.19	*	*	*	*	*	*	*	*	*	*	
	3500	310	0.32	414	0.54	504	0.79	584	1.06	656	1.35	724	1.47	785	1.74	*	*	*	*	*	*	
	4000	322	0.42	419	0.65	505	0.91	582	1.21	652	1.52	719	1.66	780	1.95	836	2.25	889	2.55	*	*	
	4500	337	0.53	428	0.78	509	1.06	582	1.37	650	1.70	714	1.86	775	2.17	831	2.49	884	2.82	935	3.16	
	5000	353	0.67	439	0.93	515	1.23	585	1.55	651	1.89	712	2.09	771	2.41	826	2.75	879	3.10	929	3.46	
	5500	369	0.84	452	1.12	524	1.43	591	1.76	654	2.12	712	2.35	769	2.69	823	3.04	875	3.41	925	3.78	
	6000	387	1.03	466	1.33	535	1.65	599	2.00	659	2.38	715	2.64	769	2.99	822	3.36	872	3.75	921	4.14	
	6500	X	X	480	1.58	547	1.92	608	2.28	666	2.67	719	2.97	772	3.34	823	3.72	872	4.12	919	4.53	
	7000	X	X	496	1.86	560	2.22	619	2.59	675	3.02	726	3.33	777	3.72	826	4.12	873	4.53	919	4.96	
	7500	X	X	513	2.17	575	2.55	631	2.95	685	3.36	735	3.74	783	4.15	831	4.56	879	4.99	921	5.43	
	8000	X	X	X	X	590	2.93	645	3.34	696	3.77	745	4.19	792	4.62	837	5.05	881	5.49	925	5.95	
	8500	X	X	X	X	605	3.35	659	3.78	709	4.23	756	4.69	801	5.13	845	5.58	888	6.04	930	6.51	
	9000	X	X	X	X	622	3.81	674	4.26	722	4.73	768	5.23	812	5.69	855	6.16	896	6.64	937	7.13	
9500	X	X	X	X	X	X	689	4.79	736	5.28	781	5.81	824	6.30	866	6.79	906	7.29				
10000	X	X	X	X	X	X	705	5.37	751	5.88	795	6.45	837	6.96	877	7.47						

Modelo Model	CFM	2.75"		3.00"		3.25"		3.5"		3.75"	
		RPM	BHP	RPM	BHP	RPM	BHP	RPM	BHP	RPM	BHP
DI-18/18 Cont.	3000	*	*	*	*	*	*	*	*	*	*
	3500	*	*	*	*	*	*	*	*	*	*
	4000	*	*	*	*	*	*	*	*	*	*
	4500	983	3.50	1028	3.85	*	*	*	*	*	*
	5000	977	3.82	1023	4.20	1067	4.58	*	*	*	*
	5500	972	4.17	1018	4.56	1062	4.96	1104	5.37	1145	5.79
	6000	968	4.54	1013	4.95	1057	5.37	1099	5.80	1140	6.24
	6500	965	4.95	1009	5.38	1052	5.81	1094	6.29	1135	6.71
	7000	964	5.39	1007	5.84	1049	6.29	1090	6.75	1130	7.22
	7500	964	5.88	1007	6.34	1048	6.81	1088	7.29		
	8000	967	6.41	1008	6.88	1048	7.37				
	8500	971	6.99	1011	7.48						
	9000	976	7.62								
	9500										
10000											

\* Funcionamiento no estable y no recomendado  
Performance is unstable and not recommended

x Funcionamiento es por debajo del 10% de eficiencia estática  
Performance is below 10% static efficiency

• Para especificaciones técnicas de modelos CAB-DI-20/20 al CAB-DI-36/36, ver curvas de operaciones  
For performance data of models CAB-DI-20/20 to CAB-DI-36/36, see operation curves.

# CAB-DI 9/6

Curvas de operación / Performance curves

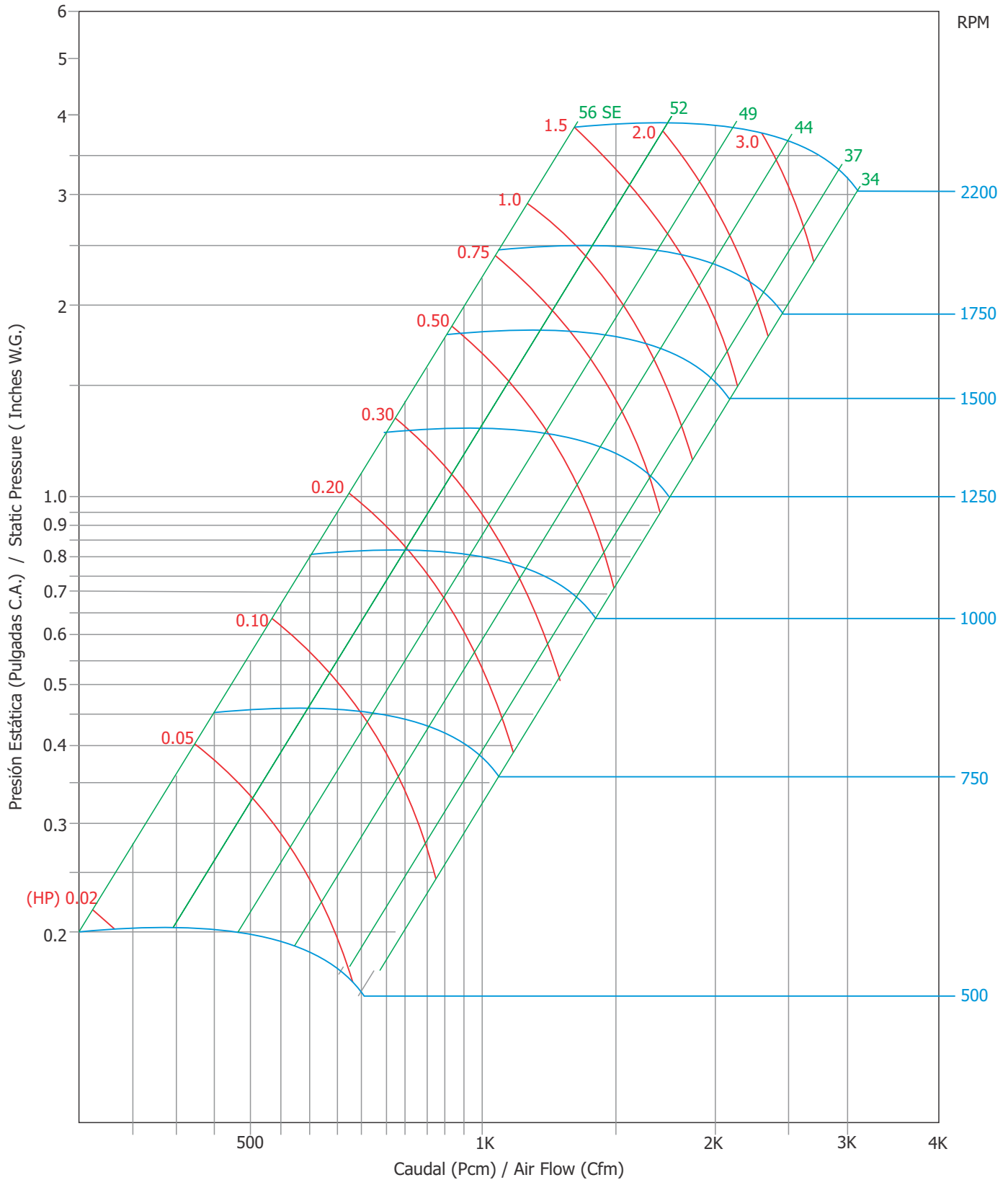

Todas las capacidades están basadas en la Densidad Estándar de Aire de 0.075 Lb/ft<sup>3</sup> @ 70°F y 0 pies de Elevación: 1.2 kg/m<sup>3</sup> @ 21°C y 0 mt  
 (All Capacities are based on Standard Air Density of 0.075 Lb/ft<sup>3</sup> @ 70°F and 0 Ft elevation: 1.2 kg/m<sup>3</sup> @ 21°C and 0 mt)

# CAB-DI 9/9

Curvas de operación / Performance curves

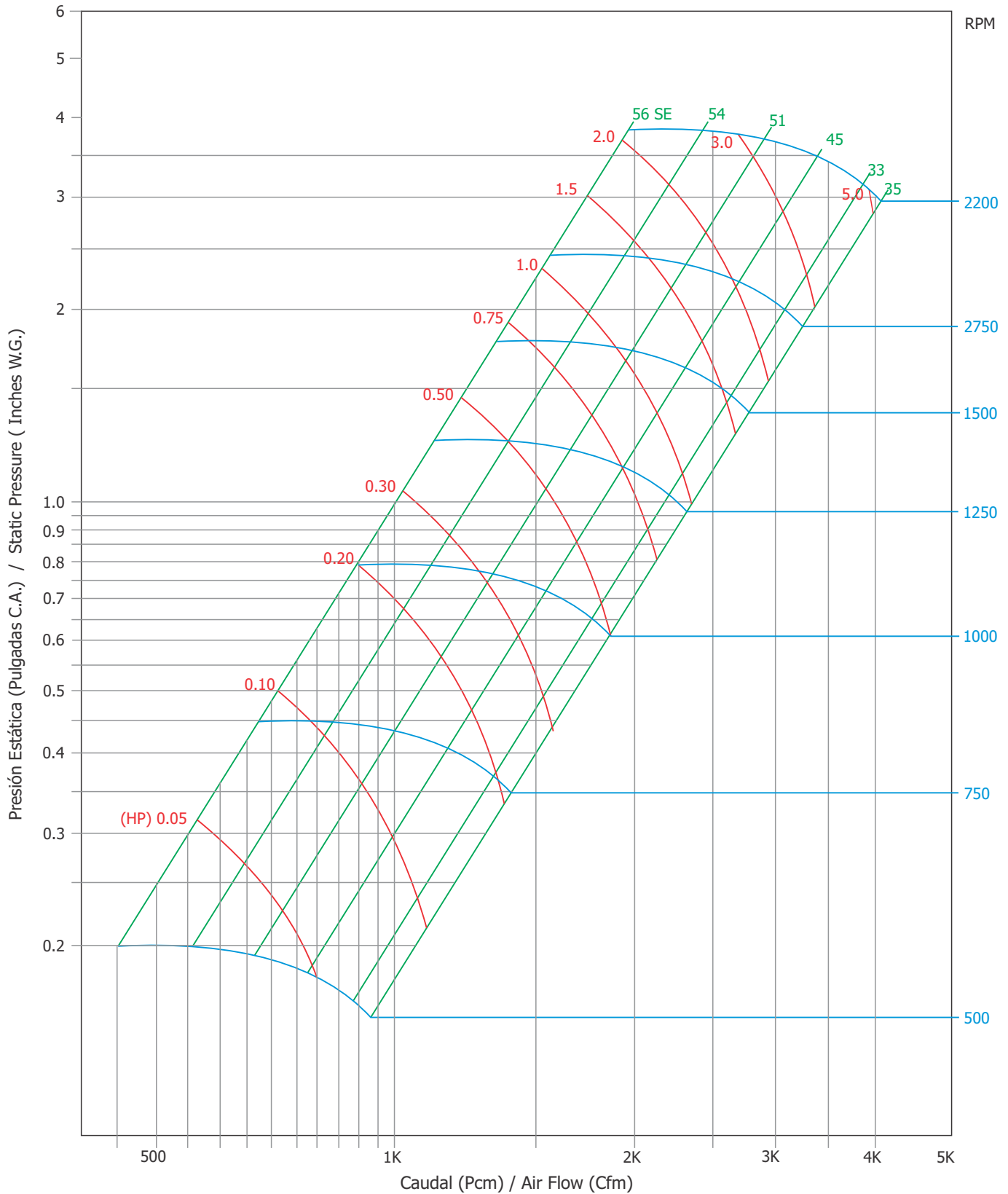

Todas las capacidades están basadas en la Densidad Estándar de Aire de 0.075 Lb/ft<sup>3</sup> @ 70°F y 0 pies de Elevación: 1.2 kg/m<sup>3</sup> @ 21°C y 0 mt  
 (All Capacities are based on Standard Air Density of 0.075 Lb/ft<sup>3</sup> @ 70°F and 0 Ft elevation: 1.2 kg/m<sup>3</sup> @ 21°C and 0 mt)

# CAB-DI 10/10

Curvas de operación / Performance curves

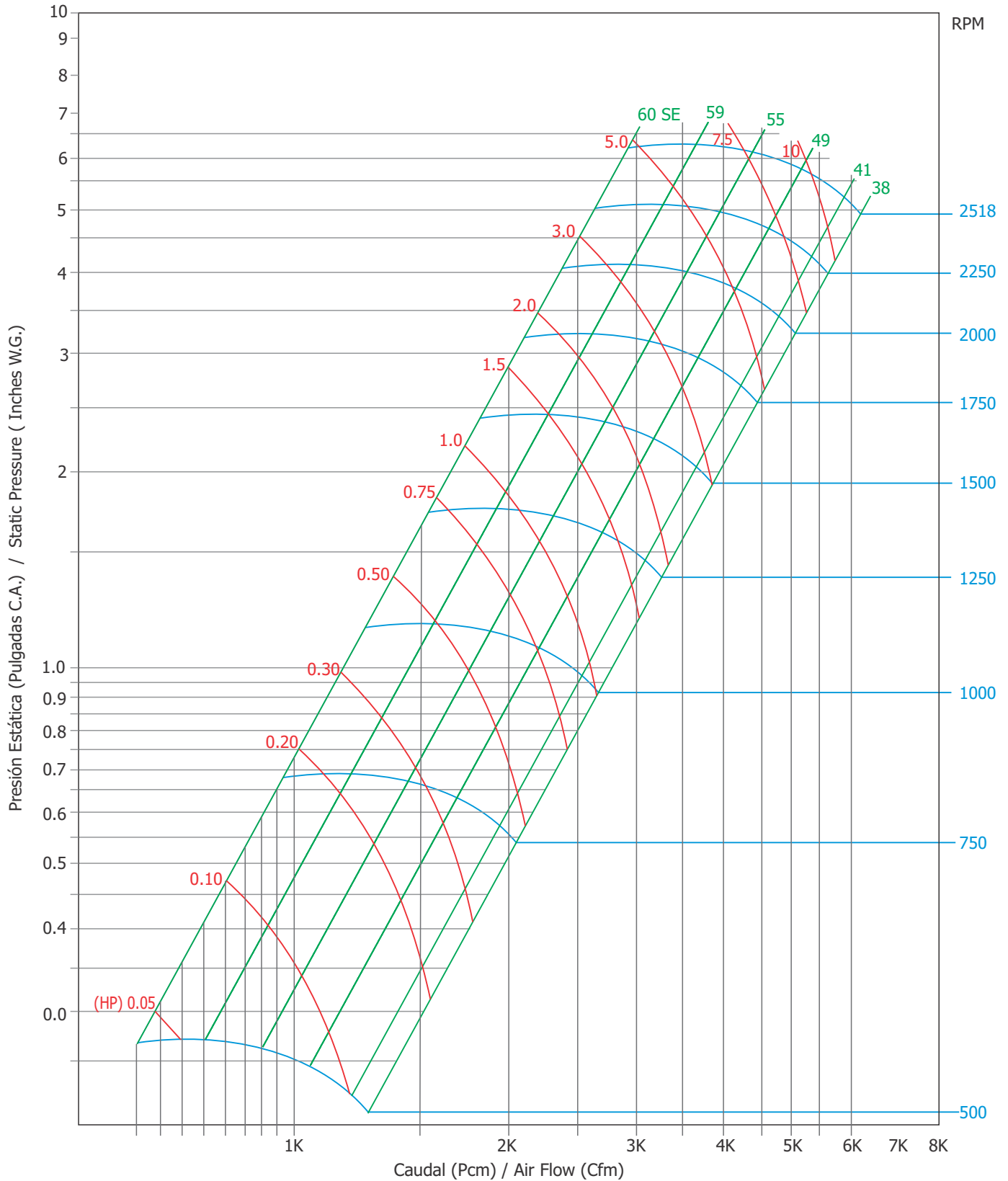

Todas las capacidades están basadas en la Densidad Estándar de Aire de 0.075 Lb/ft<sup>3</sup> @ 70°F y 0 pies de Elevación: 1.2 kg/m<sup>3</sup> @ 21°C y 0 mt  
 (All Capacities are based on Standard Air Density of 0.075 Lb/ft<sup>3</sup> @ 70°F and 0 Ft elevation: 1.2 kg/m<sup>3</sup> @ 21°C and 0 mt)

# CAB-DI 12/12

Curvas de operación / Performance curves

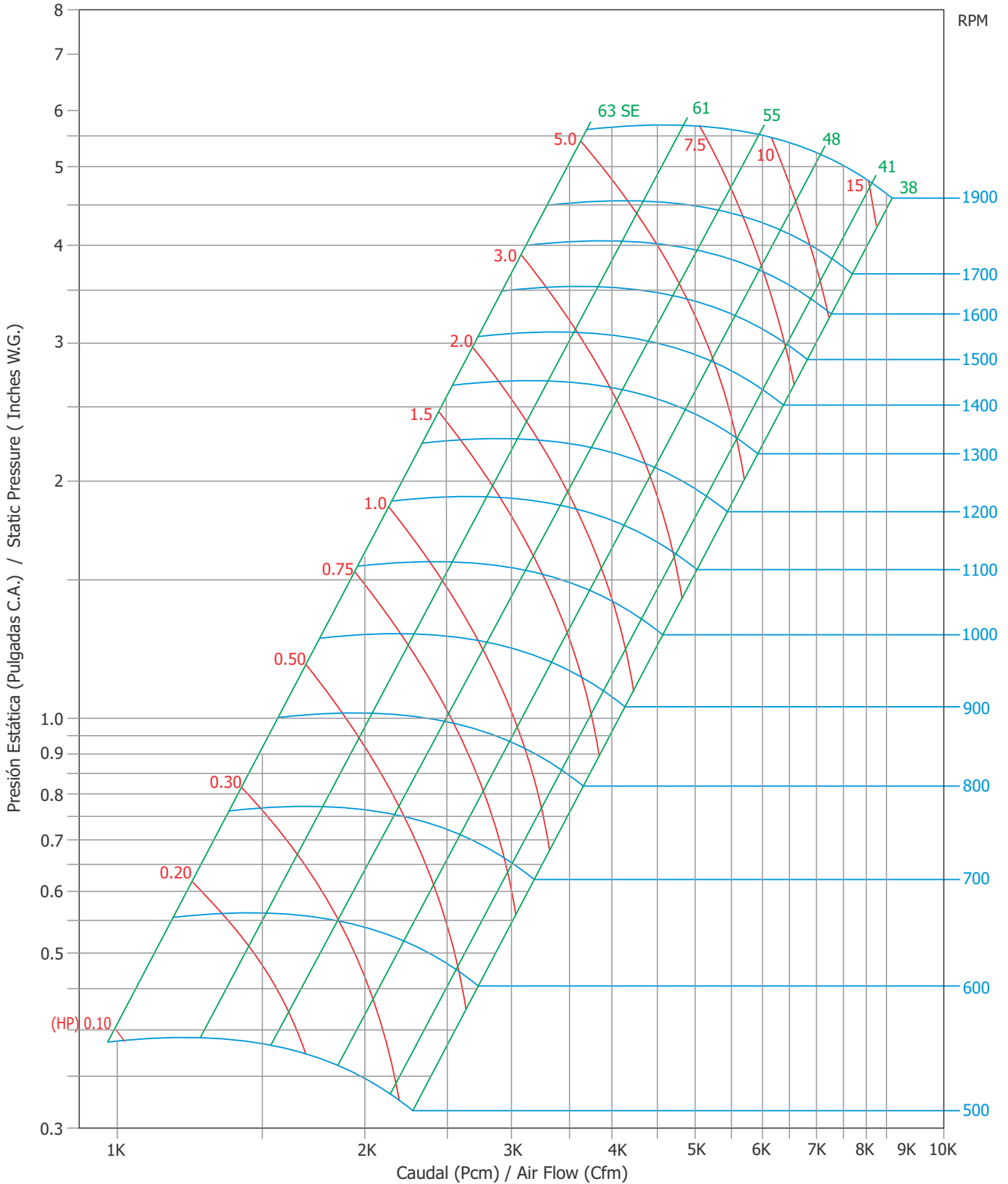

Todas las capacidades están basadas en la Densidad Estándar de Aire de 0.075 Lb/ft<sup>3</sup> @ 70°F y 0 pies de Elevación: 1.2 kg/m<sup>3</sup> @ 21°C y 0 mt  
 (All Capacities are based on Standard Air Density of 0.075 Lb/ft<sup>3</sup> @ 70°F and 0 Ft elevation: 1.2 kg/m<sup>3</sup> @ 21°C and 0 mt)

# CAB-DI 15/15

Curvas de operación / Performance curves

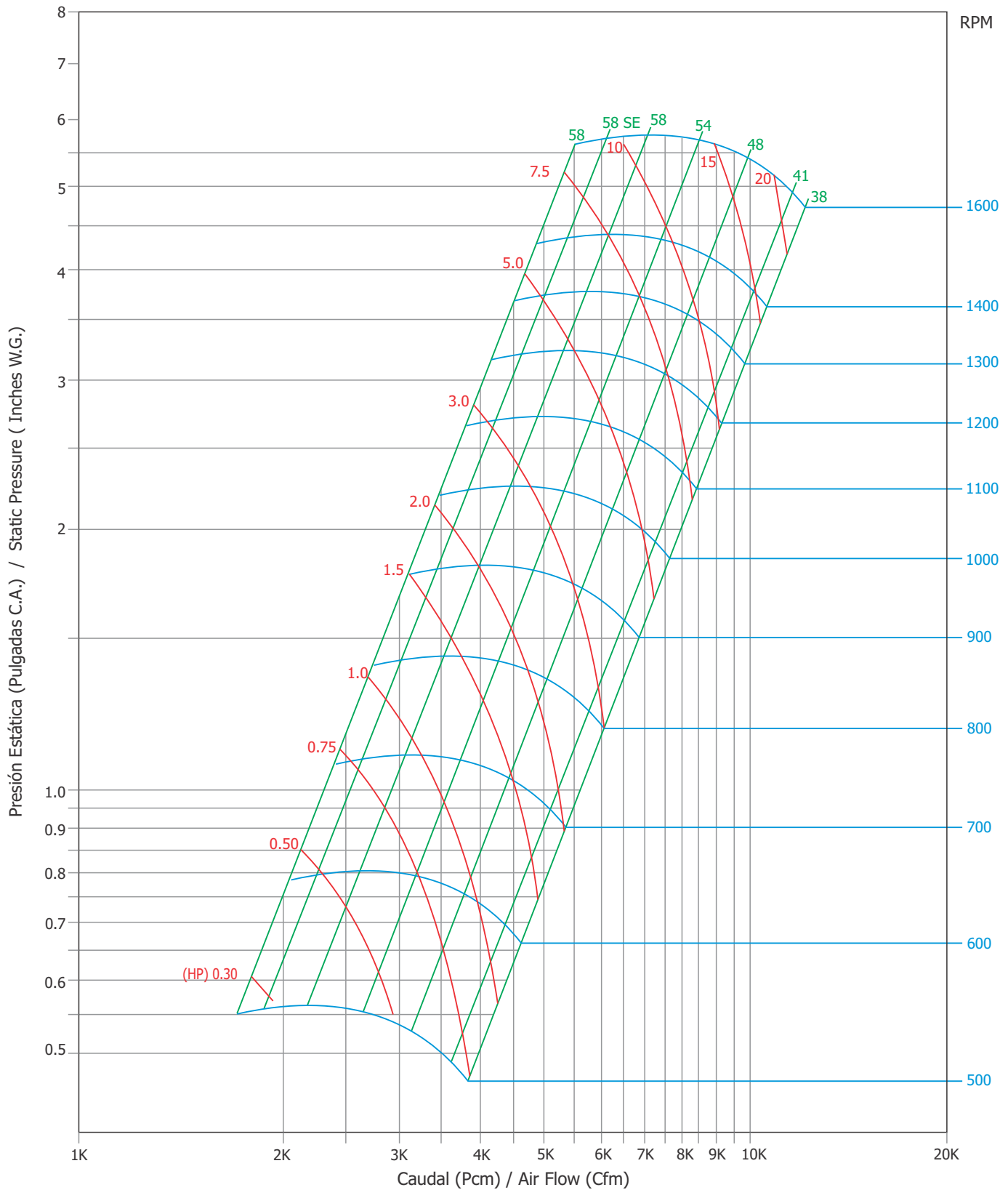

Todas las capacidades están basadas en la Densidad Estándar de Aire de 0.075 Lb/ft<sup>3</sup> @ 70°F y 0 pies de Elevación: 1.2 kg/m<sup>3</sup> @ 21°C y 0 mt  
 (All Capacities are based on Standard Air Density of 0.075 Lb/ft<sup>3</sup> @ 70°F and 0 Ft elevation: 1.2 kg/m<sup>3</sup> @ 21°C and 0 mt)

# CAB-DI 18/18

Curvas de operación / Performance curves

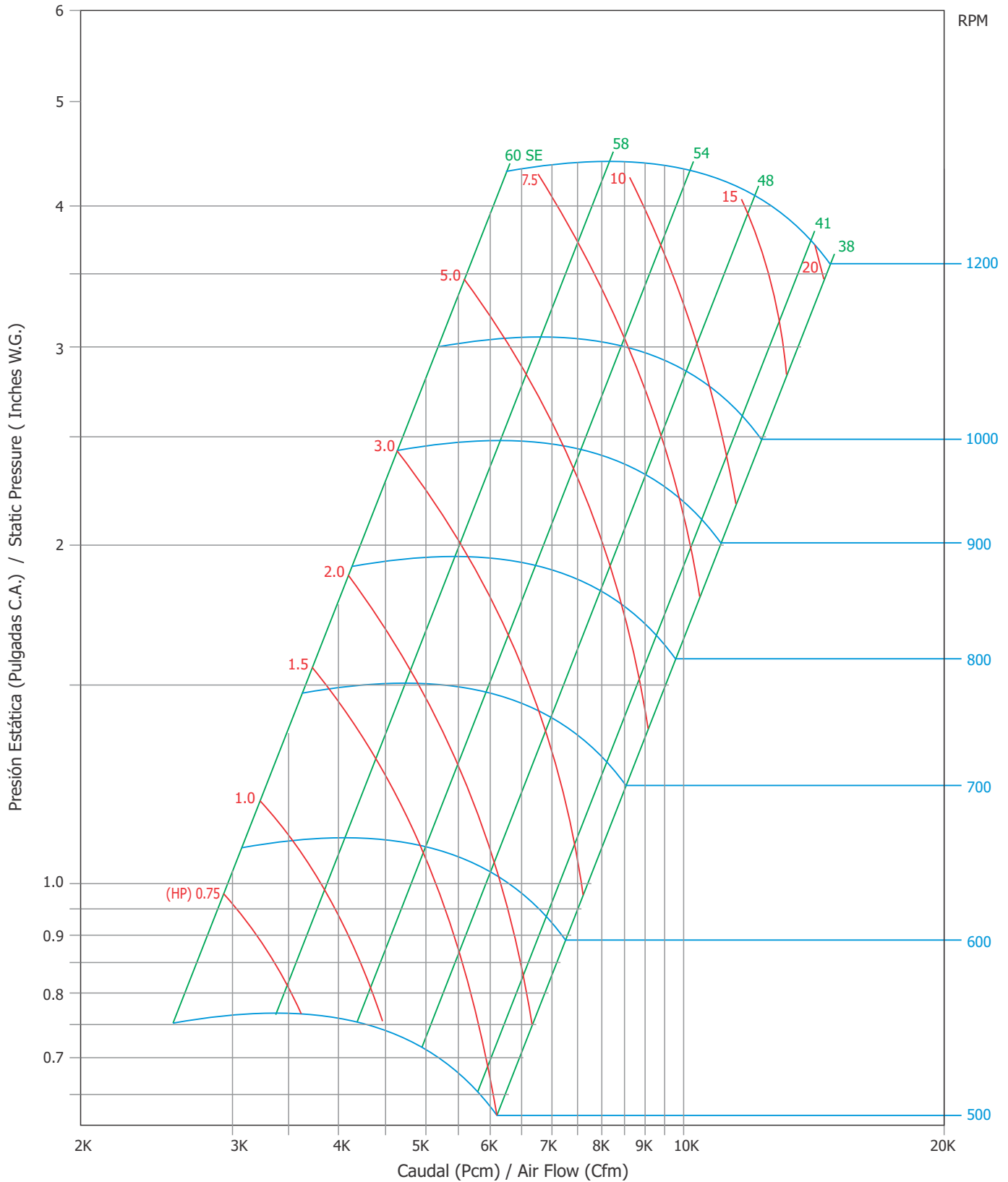

Todas las capacidades están basadas en la Densidad Estándar de Aire de 0.075 Lb/ft<sup>3</sup> @ 70°F y 0 pies de Elevación: 1.2 kg/m<sup>3</sup> @ 21°C y 0 mt  
 (All Capacities are based on Standard Air Density of 0.075 Lb/ft<sup>3</sup> @ 70°F and 0 Ft elevation: 1.2 kg/m<sup>3</sup> @ 21°C and 0 mt)

# CAB-DI 20/20

Curvas de operación / Performance curves

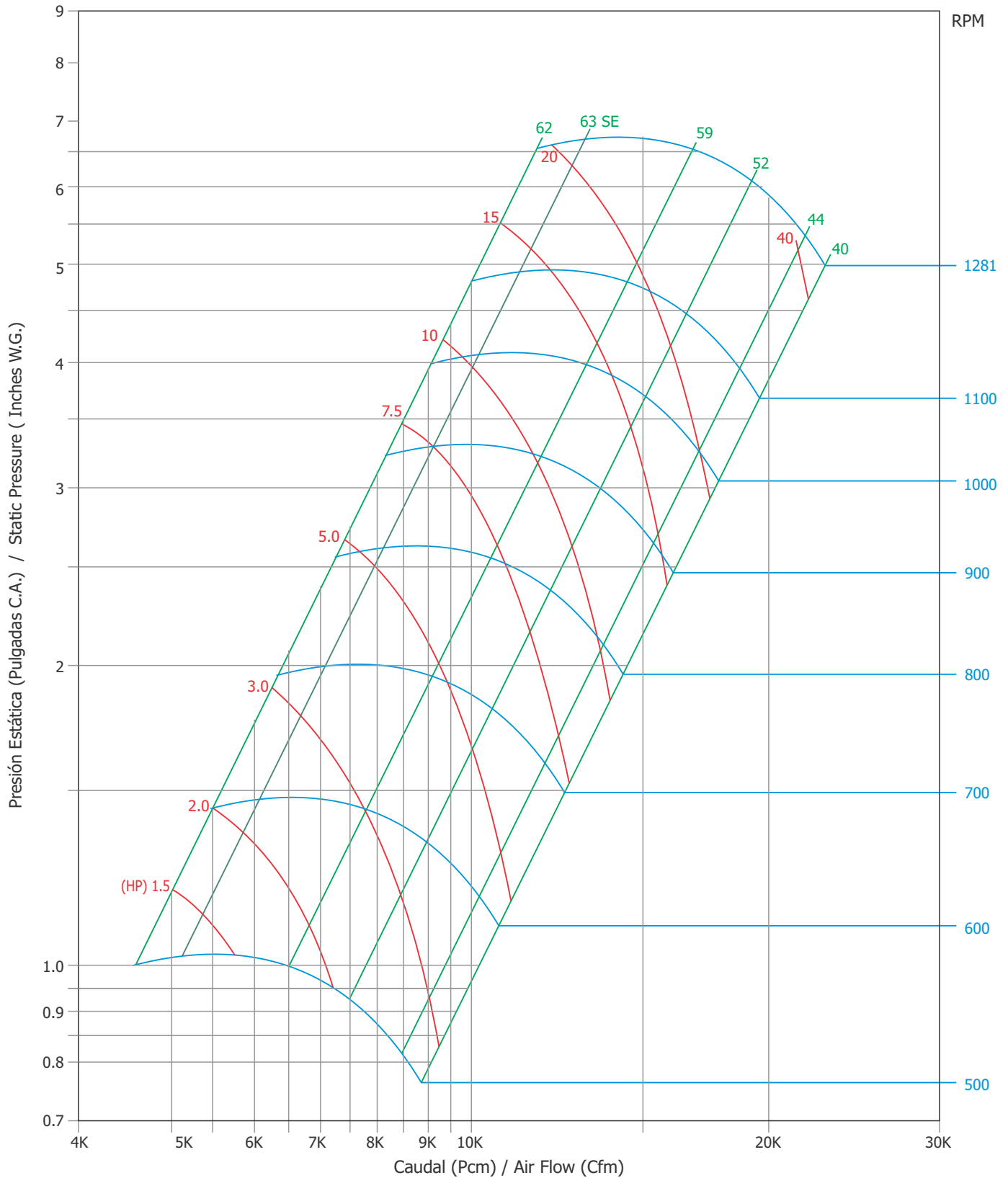

Todas las capacidades están basadas en la Densidad Estándar de Aire de 0.075 Lb/ft<sup>3</sup> @ 70°F y 0 pies de Elevación: 1.2 kg/m<sup>3</sup> @ 21°C y 0 mt  
 (All Capacities are based on Standard Air Density of 0.075 Lb/ft<sup>3</sup> @ 70°F and 0 Ft elevation: 1.2 kg/m<sup>3</sup> @ 21°C and 0 mt)

# CAB-DI 22/22

Curvas de operación / Performance curves

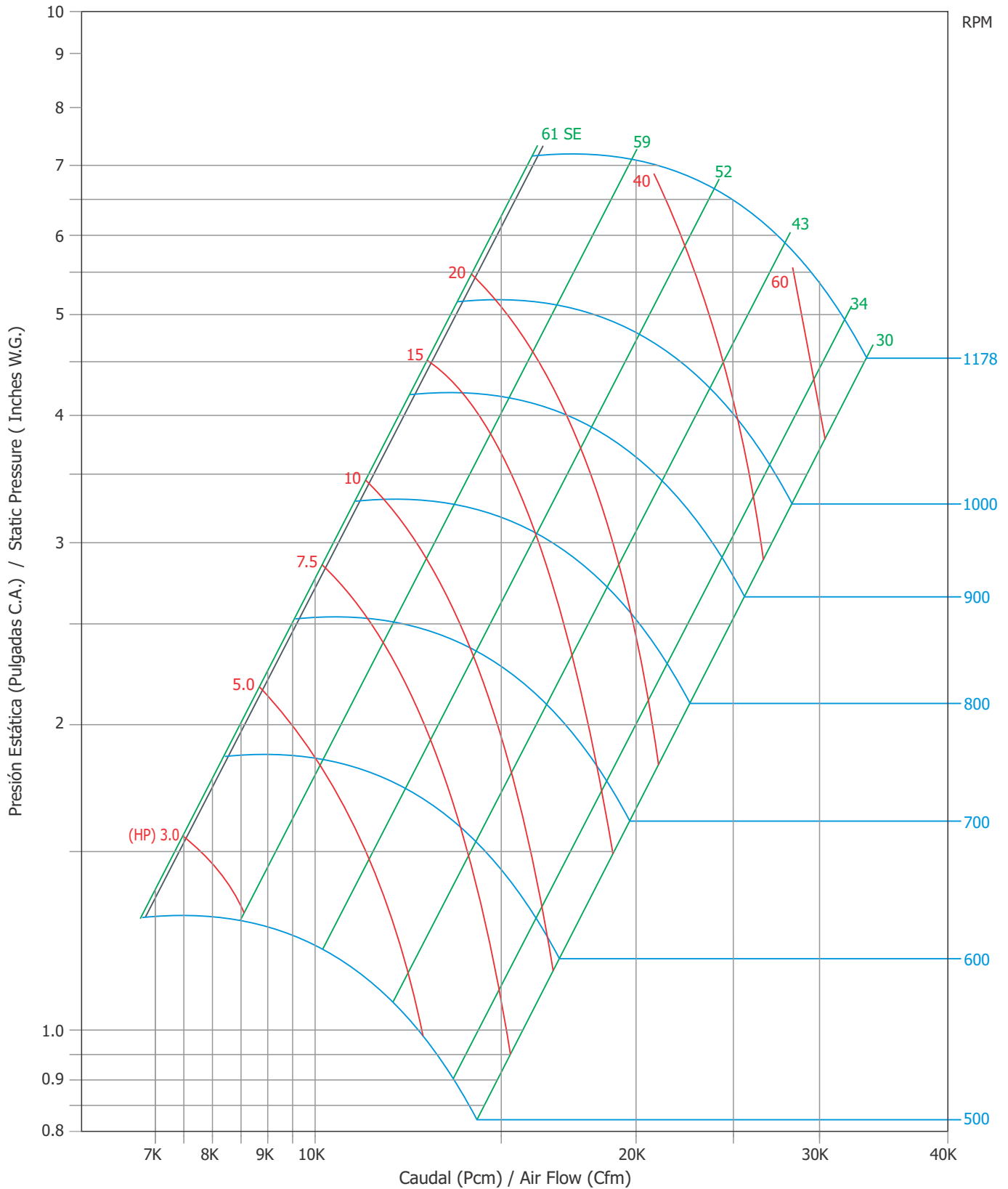

Todas las capacidades están basadas en la Densidad Estándar de Aire de 0.075 Lb/ft<sup>3</sup> @ 70°F y 0 pies de Elevación: 1.2 kg/m<sup>3</sup> @ 21°C y 0 mt  
 (All Capacities are based on Standard Air Density of 0.075 Lb/ft<sup>3</sup> @ 70°F and 0 Ft elevation: 1.2 kg/m<sup>3</sup> @ 21°C and 0 mt)

# CAB-DI 25/25

Curvas de operación / Performance curves

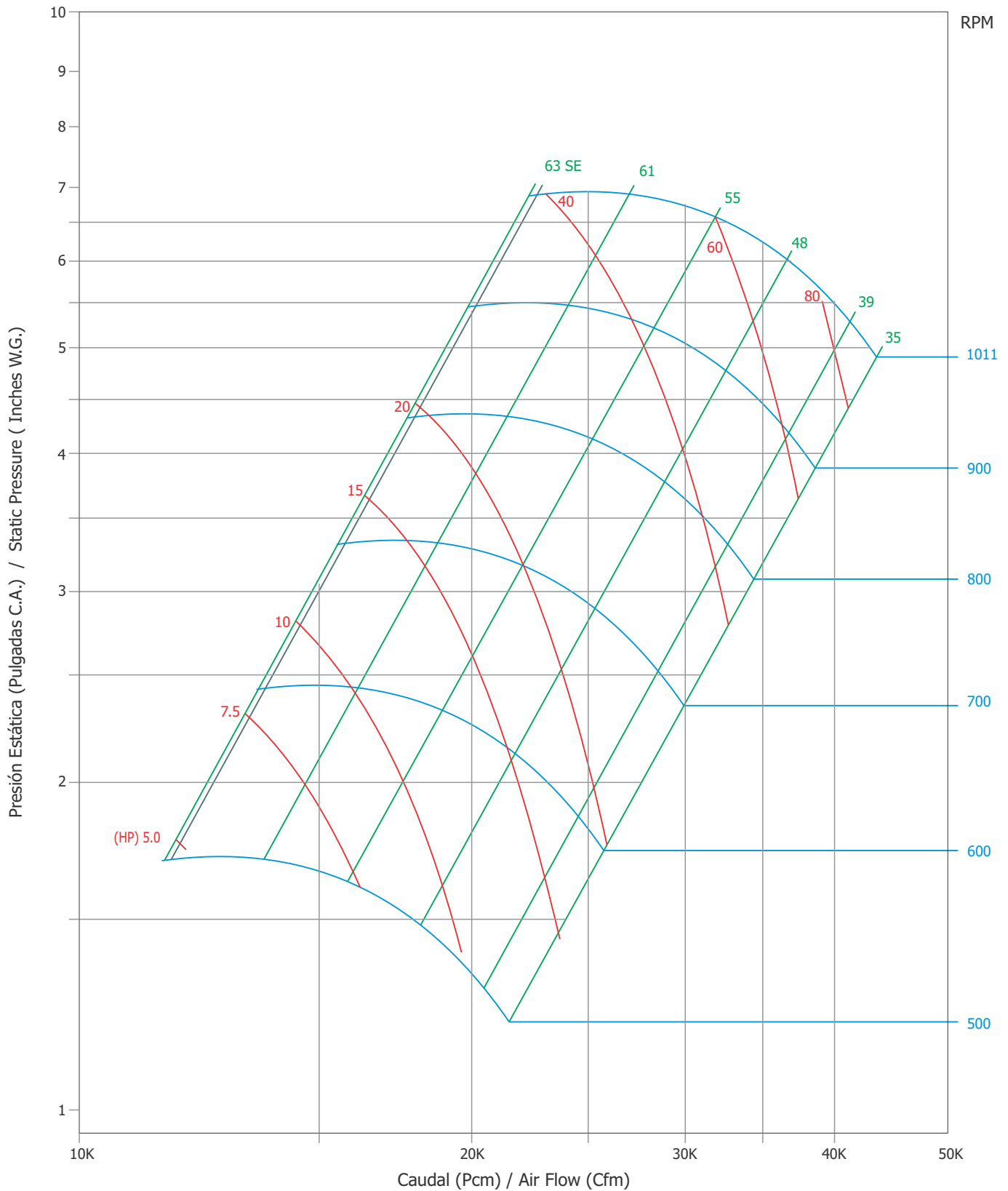

Todas las capacidades están basadas en la Densidad Estándar de Aire de 0.075 Lb/ft<sup>3</sup> @ 70°F y 0 pies de Elevación: 1.2 kg/m<sup>3</sup> @ 21°C y 0 mt  
 (All Capacities are based on Standard Air Density of 0.075 Lb/ft<sup>3</sup> @ 70°F and 0 Ft elevation: 1.2 kg/m<sup>3</sup> @ 21°C and 0 mt)

# CAB-DI 30/30

Curvas de operación / Performance curves

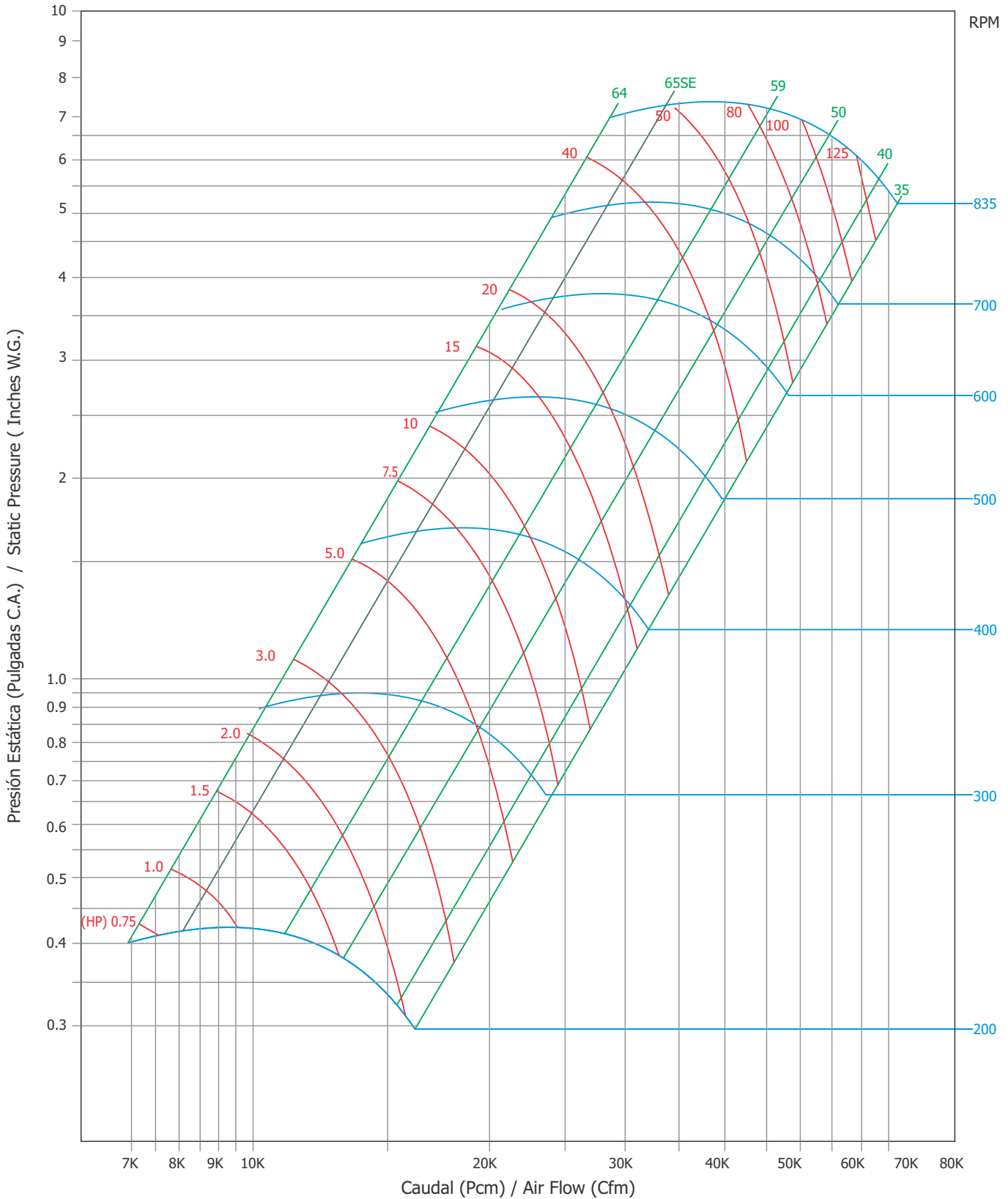

Todas las capacidades están basadas en la Densidad Estándar de Aire de 0.075 Lb/ft<sup>3</sup> @ 70°F y 0 pies de Elevación: 1.2 kg/m<sup>3</sup> @ 21°C y 0 mt  
 (All Capacities are based on Standard Air Density of 0.075 Lb/ft<sup>3</sup> @ 70°F and 0 Ft elevation: 1.2 kg/m<sup>3</sup> @ 21°C and 0 mt)

# CAB-DI 36/36

Curvas de operación / Performance curves

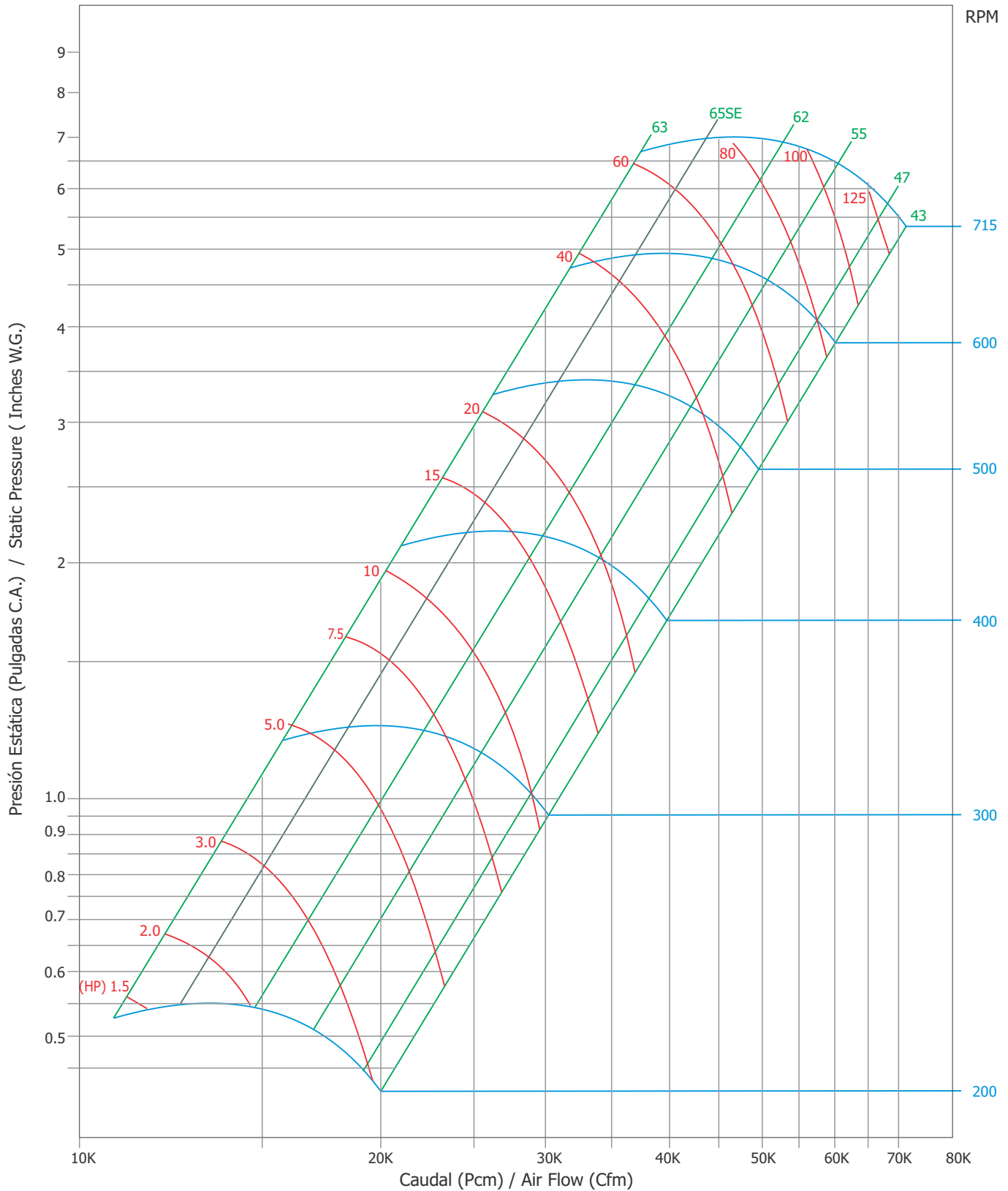

Todas las capacidades están basadas en la Densidad Estándar de Aire de 0.075 Lb/ft<sup>3</sup> @ 70°F y 0 pies de Elevación: 1.2 kg/m<sup>3</sup> @ 21°C y 0 mt  
 (All Capacities are based on Standard Air Density of 0.075 Lb/ft<sup>3</sup> @ 70°F and 0 Ft elevation: 1.2 kg/m<sup>3</sup> @ 21°C and 0 mt)

# CAB-DIH

## Dimensiones generales / Dimensions



Arreglo 3I. Modelos: 9/6 al 18/18  
 Arrangement 3I. Models: 9/6 to 18/18

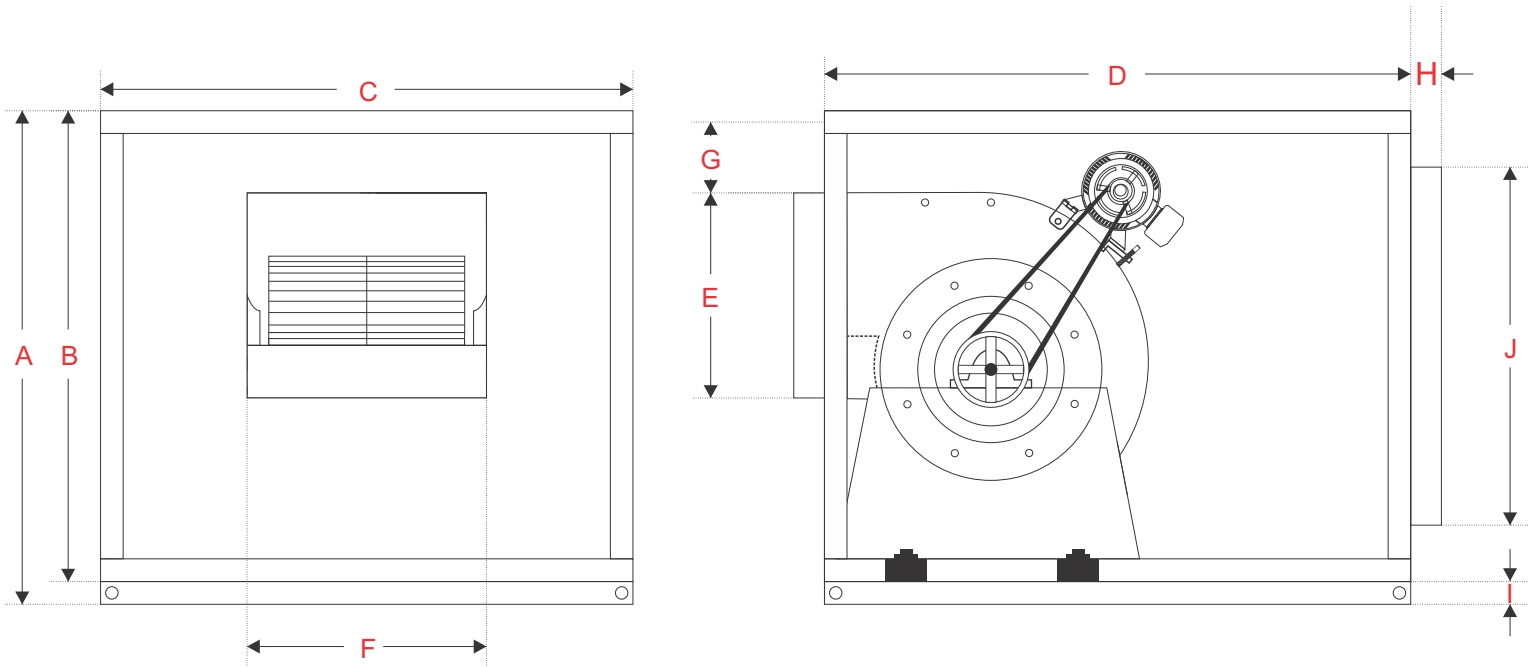

Modelo	Pulgadas/Inches											# Puertas	Filtros / Filters	
Model	A	B	C	D	E	F	G	H	I	J	K	# Doors	#	L"xW"xH"
DIH-9/6	30	27	27	36	10 1/4	9	5 13/16	2	3	13 5/8	6 11/16	1	1	24x24x2
DIH-9/9	30	27	27	36	10 1/4	12 5/8	5 13/16	2	3	13 5/8	6 11/16	1	1	24x24x2
DIH-10/10	46	43	43	45	11 3/8	14	19 7/8	2	3	19 5/8	11 11/16	1	4	20x20x2
DIH-12/12	46	43	43	45	13 7/16	16 1/2	16 7/8	2	3	19 5/8	11 11/16	1	4	20x20x2
DIH-15/15	46	43	43	48	15 7/8	19	13	2	3	27 1/2	7 3/4	1	4	20x20x2
DIH-18/18	55	52	51	54	18 7/8	22 3/4	17 1/16	2	3	27 1/2	7 3/4	1	4	24x24x2

# CAB-DIH



## Dimensiones generales / Dimensions

Arreglo 3B. Modelos: 9/6 al 18/18  
 Arrangement 3B. Models: 9/6 to 18/18

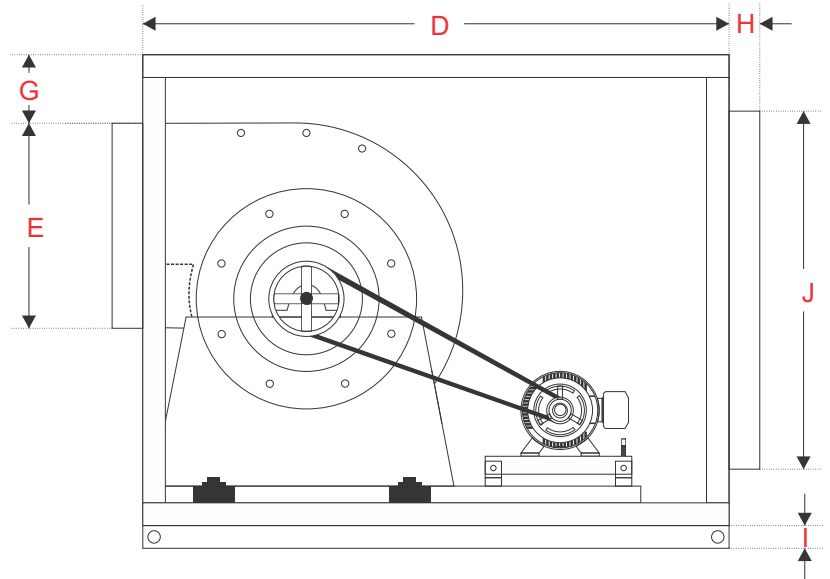
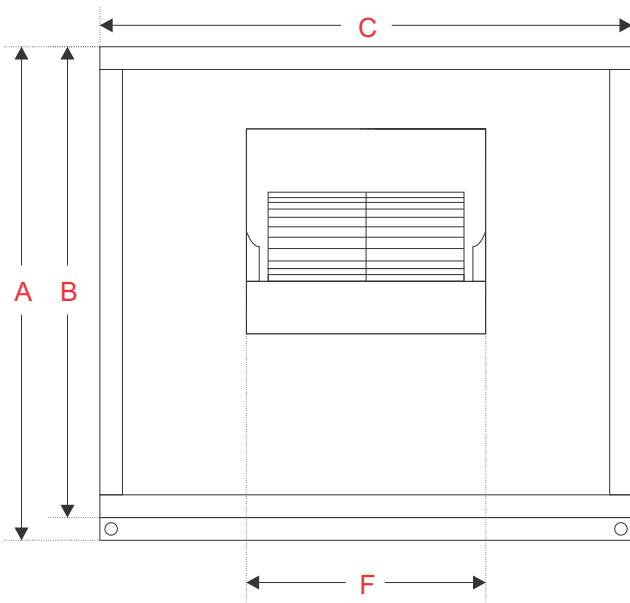

Modelo	Pulgadas/Inches											# Puertas	Filtros / Filters	
	A	B	C	D	E	F	G	H	I	J	K		# Doors	#
DIH-9/6	30	27	27	36	10 1/4	9	5 13/16	2	3	13 5/8	6 11/16	1	1	24x24x2
DIH-9/9	30	27	27	36	10 1/4	12 5/8	5 13/16	2	3	13 5/8	6 11/16	1	1	24x24x2
DIH-10/10	46	43	43	45	11 3/8	14	19 7/8	2	3	19 5/8	11 11/16	1	4	20x20x2
DIH-12/12	46	43	43	45	13 7/16	16 1/2	16 7/8	2	3	19 5/8	11 11/16	1	4	20x20x2
DIH-15/15	46	43	43	48	15 7/8	19	13	2	3	27 1/2	7 3/4	1	4	20x20x2
DIH-18/18	55	52	51	54	18 7/8	22 3/4	17 1/16	2	3	27 1/2	7 3/4	1	4	24x24x2

# CAB-DIH

## Dimensiones generales / Dimensions



Arreglo 3B. Modelos: 20/20 al 36/36

Arrangement 3B. Models: 20/20 to 36/36

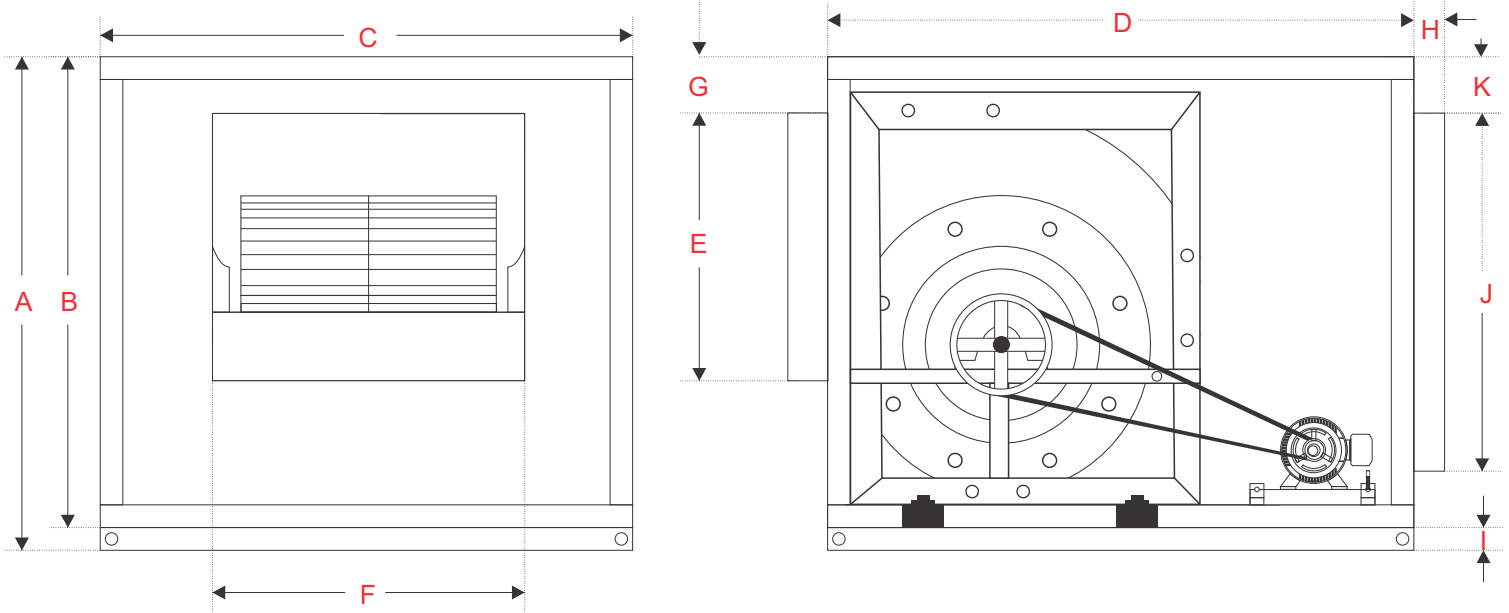

Modelo	Pulgadas/Inches											# Puertas	Filtros / Filters	
Model	A	B	C	D	E	F	G	H	I	J	K	# Doors	#	L"xW"xH"
DIH-20/20	55	52	60	63	24 3/4	28 3/4	10 7/8	2	3	31 1/2	10 1/4	2	6	20x20x2
DIH-22/22	58	55	66	75	27 1/4	31 1/4	10 1/4	2	3	35 5/8	9 11/16	2	6	24x24x2
DIH-25/25	67	64	75	70	31 1/4	35 1/4	14	2 3/4	3	39 1/4	12 3/8	2	12	20x20x2
DIH-30/30	68	65	90	76	37	40 3/4	6 1/4	2 3/4	3	47 1/4	8 7/8	2	12	24x24x2
DIH-36/36	87	84	98	88	42 15/16	46 3/4	8 7/8	2 3/4	3	61 1/2	11 1/4	2	18	24x24x2

# CAB-DIV



## Dimensiones generales / Dimensions

Arreglo 3I. Modelos: 9/6 al 18/18

Arrangement 3I. Models: 9/6 to 18/18

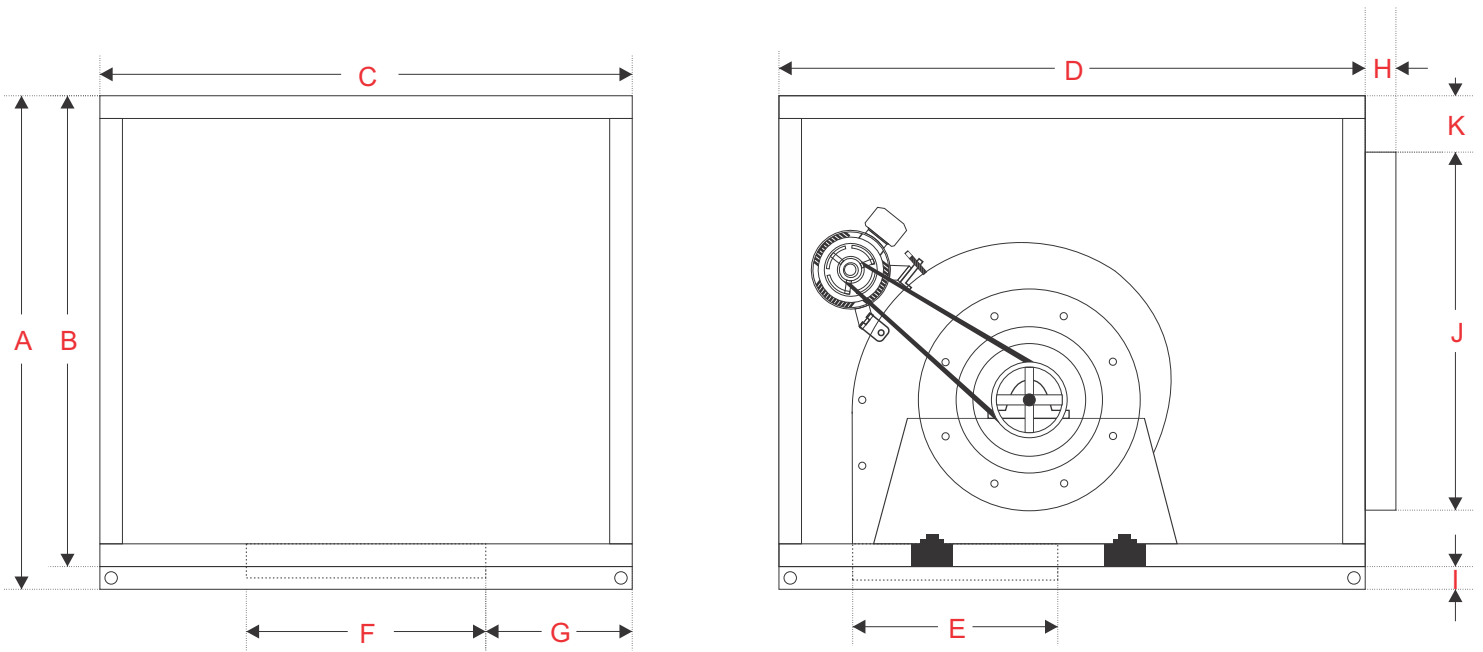

Modelo	Pulgadas/Inches											# Puertas	Filtros / Filters	
Model	A	B	C	D	E	F	G	H	I	J	K	# Doors	#	L"xW"xH"
DIV-9/6	30	27	27	36	10 1/4	9	9	2	3	13 5/8	6 11/16	1	1	24x24x2
DIV-9/9	30	27	27	36	10 1/4	12 5/8	7 3/16	2	3	13 5/8	6 11/16	1	1	24x24x2
DIV-10/10	46	43	43	45	11 3/8	14	14 1/2	2	3	19 5/8	11 11/16	1	4	20x20x2
DIV-12/12	46	43	43	45	13 7/16	16 1/2	13 1/4	2	3	19 5/8	11 11/16	1	4	20x20x2
DIV-15/15	46	43	43	48	15 7/8	19	12	2	3	27 1/2	7 3/4	1	4	20x20x2
DIV-18/18	55	52	51	54	18 7/8	22 3/4	14 1/8	2	3	27 1/2	7 3/4	1	4	24x24x2

# CAB-DIV



## Dimensiones generales / Dimensions

Arreglo 3B. Modelos: 9/6 al 18/18

Arrangement 3B. Models: 9/6 to 18/18

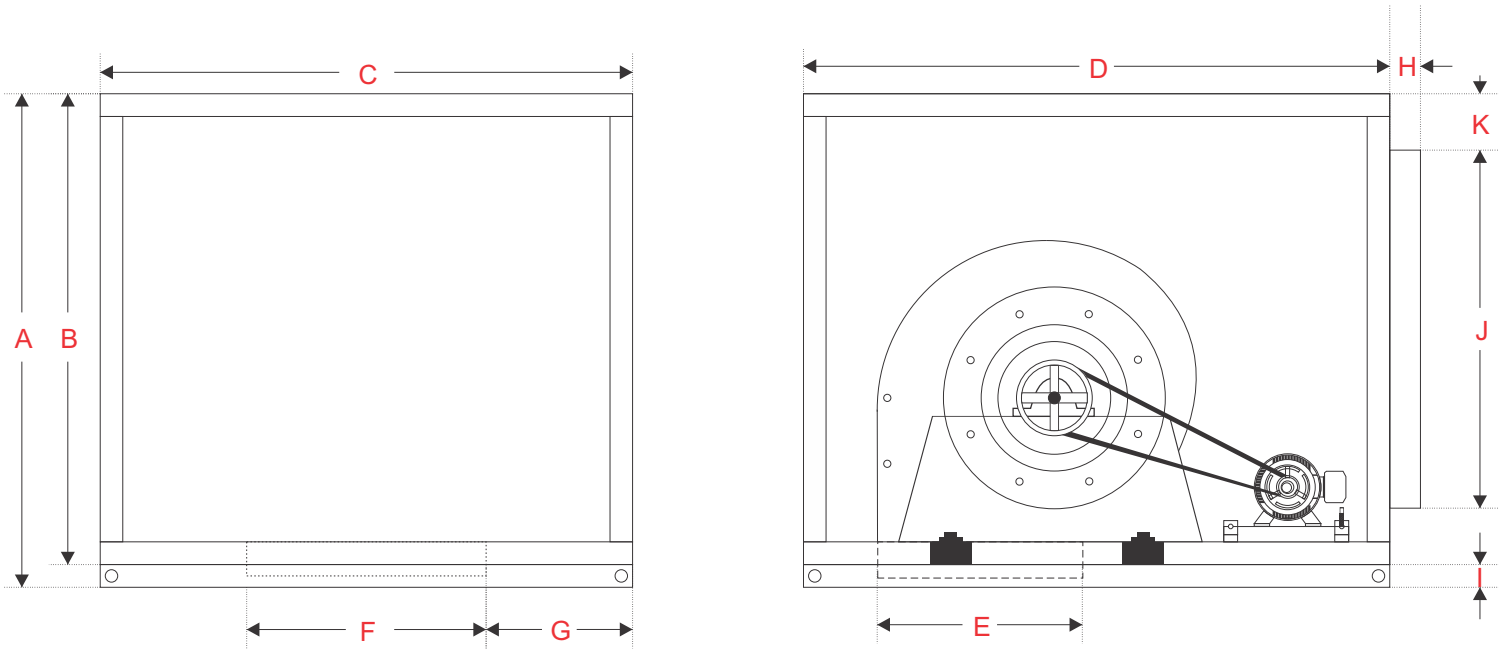

Modelo	Pulgadas/Inches											# Puertas	Filtros / Filters	
Model	A	B	C	D	E	F	G	H	I	J	K	# Doors	#	L"xW"xH"
DIV-9/6	30	27	27	36	10 1/4	9	9	2	3	13 5/8	6 11/16	1	1	24x24x2
DIV-9/9	30	27	27	36	10 1/4	12 5/8	7 3/16	2	3	13 5/8	6 11/16	1	1	24x24x2
DIV-10/10	46	43	43	45	11 3/8	14	14 1/2	2	3	19 5/8	11 11/16	1	4	20x20x2
DIV-12/12	46	43	43	45	13 7/16	16 1/2	13 1/4	2	3	19 5/8	11 11/16	1	4	20x20x2
DIV-15/15	46	43	43	48	15 7/8	19	12	2	3	27 1/2	7 3/4	1	4	20x20x2
DIV-18/18	55	52	51	54	18 7/8	22 3/4	14 1/8	2	3	27 1/2	7 3/4	1	4	24x24x2

# CAB-DIV



## Dimensiones generales / Dimensions

Arreglo 3B. Modelos: 20/20 al 36/36

Arrangement 3B. Models: 20/20 to 36/36

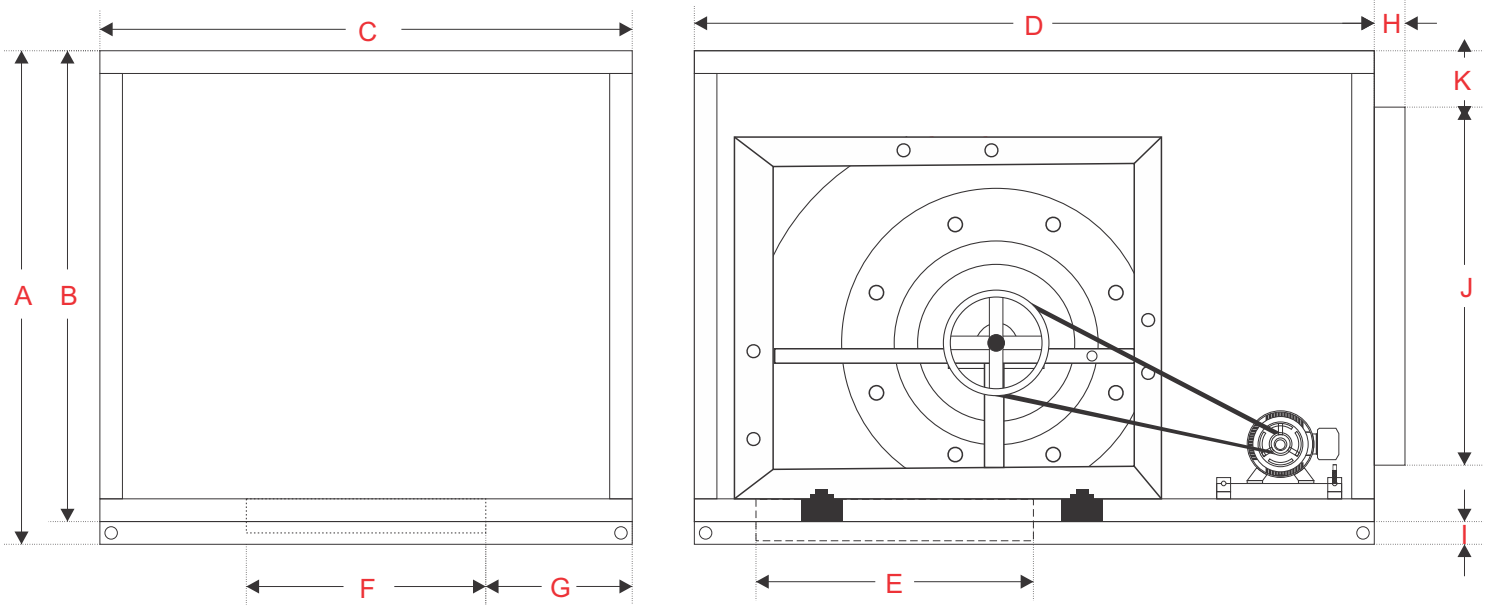

Modelo	Pulgadas/Inches											# Puertas	Filtros / Filters	
	A	B	C	D	E	F	G	H	I	J	K	# Doors	#	L"xW"xH"
DIV-20/20	55	52	60	63	24 3/4	28 3/4	15 5/8	2	3	31 1/2	10 1/4	2	6	20x20x2
DIV-22/22	58	55	66	75	27 1/4	31 1/4	17 3/8	2	3	35 5/8	9 11/16	2	6	24x24x2
DIV-25/25	67	64	75	70	31 1/4	35 1/4	19 7/8	2 3/4	3	39 1/4	12 3/8	2	12	20x20x2
DIV-30/30	68	65	90	76	37	40 3/4	24 5/8	2 3/4	3	47 1/4	8 7/8	2	12	24x24x2
DIV-36/36	87	84	98	88	42 15/16	46 3/4	25 5/8	2 3/4	3	61 1/2	11 1/4	2	18	24x24x2

# Arreglo de los filtros-louvers / Filter-louver arrangement

## CAB-DIH-F

Arreglo 3I. Modelos 9/6 al 18/18  
Arrangement 3I. Models 9/6 to 18/18

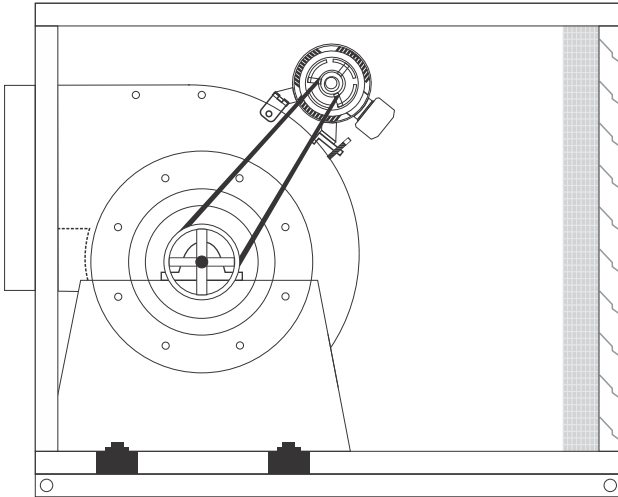

## CAB-DIH-F

Arreglo 3B. Modelos 9/6 al 18/18  
Arrangement 3B. Models 9/6 to 18/18

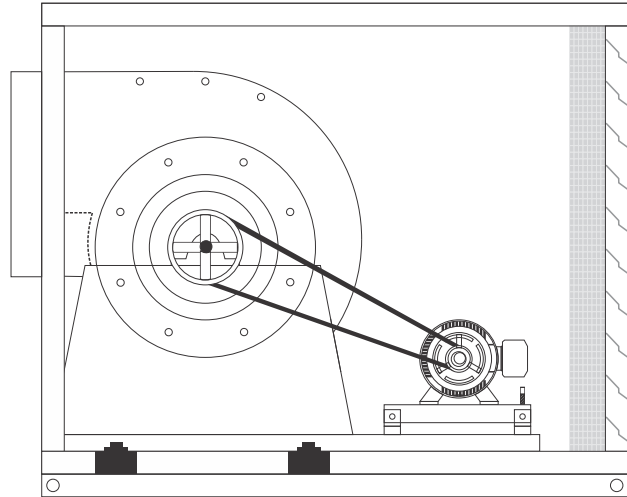

## CAB-DIV-F

Arreglo 3I. Modelos 9/6 al 18/18  
Arrangement 3I. Models 9/6 to 18/18

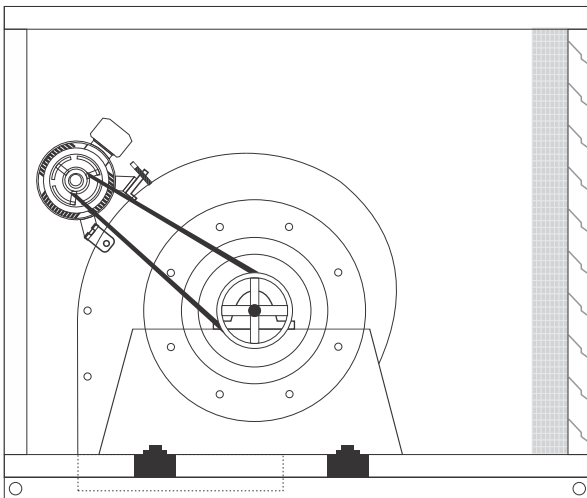

## CAB-DIV-F

Arreglo 3B. Modelos 9/6 al 18/18  
Arrangement 3B. Models 9/6 to 18/18

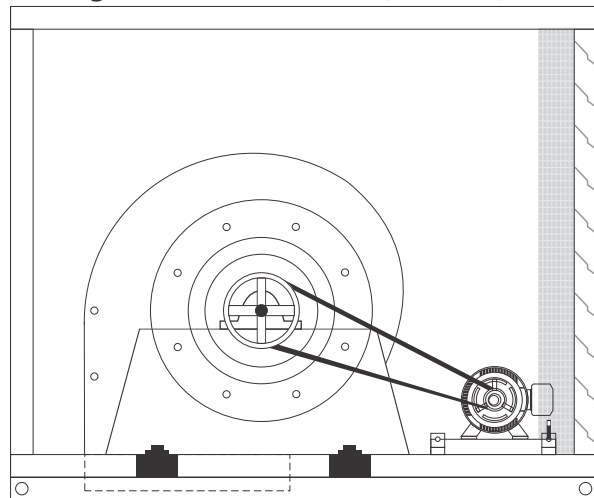

## CAB-DIH-F

Arreglo 3B. Modelos 20/20 al 36/36  
Arrangement 3B. Models 20/20 to 36/36

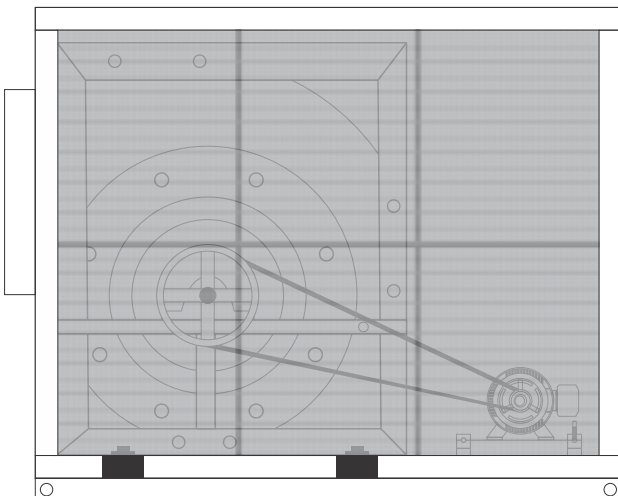

## CAB-DIV-F

Arreglo 3B. Modelos 20/20 al 36/36  
Arrangement 3B. Models 20/20 to 36/36

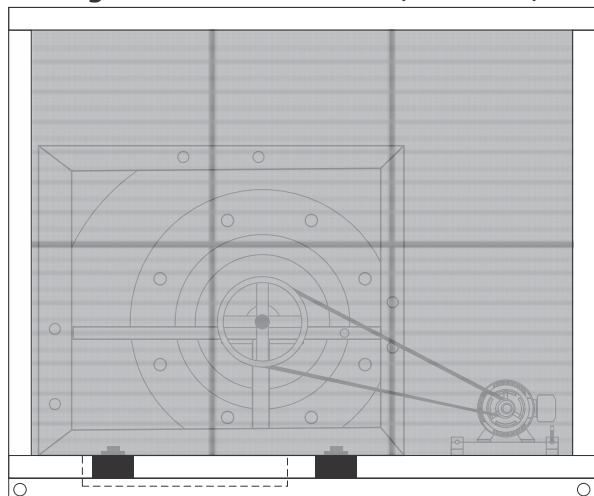

<sup>®</sup>  
**AIR**  
**TECHNOLOGY**  
CORPORATION, S.A. DE C.V.



**The  
Right  
Choice**

Air Technology se reserva el derecho de modificación sin previo aviso.

Air Technology reserves the right to change specifications without prior notice.

